

PAINT STATIONS



SPRAY TABLE

Designed as a Table Top work platform, this equipment provides a comfortable and clean work environment for small to medium size projects. The powerful 18" exhaust fan removes overspray from the work area and collects it in 99.6% "AFTL" certified efficient extraction filters, allowing only clean air to exit the workplace. The 4 tube fluorescent fixture provides excellent illumination of the work area.

EXHAUST BENCH

Designed for medium to large size projects, the space saving exhaust bench removes large quantities of overspray quickly & efficiently. The heavy duty bench top doubles as a convenient work surface and the 24"/30' exhaust fan removes contaminants away from the work area.



EXHAUST WALL

Our most popular Paint Station, this full size unit is designed for large projects. The 30" exhaust fan can be fitted with 2, 3, or 5HP motors and removes overspray quickly from the work area. Practical, but more so versatile, this Exhaust Wall is the basis from which our enclosed paint booths are built and can be expanded to an "Open Face Booth" with greater depth. It can also be expanded into a short, enclosed, "Mini" booth with entry doors, or a full size, full function Paint Booth.

FUTURE CURE

"WE'VE GOT THE ANSWERS"

800-673-2493

futurecure.com

Spray Table

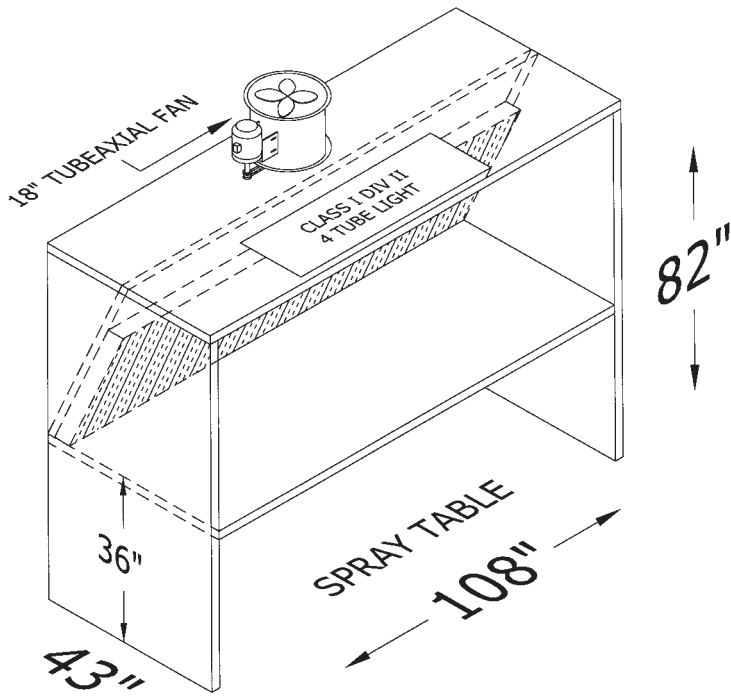

18 Gauge galvanized steel panels
 (1) 48", 4 tube, 120V, ETL Approved Fixture
 Listed for Class I, Div. II, Hazard Location
 (4) tube locations, Shipped less tubes (T8)
 Exhaust Filter "AFTL" Certified @ 99.6%
 18" Exhaust Fan, Hazard location approved
 3/4 HP, 115/230V 1 PH, TEFC, HzLo, Motor

Exhaust Benches

18 Gauge galvanized steel panels
 Exhaust Filter "AFTL" Certified @ 99.6%
EB-115
 24" Exhaust Fan, Hazard location approved
 2 HP, 208/230/460V 3PH, TEFC, HzLo, Motor
EB-230
 30" Exhaust Fan, Hazard location approved
 3 HP, 208/230/460V 3PH, TEFC, HzLo, Motor

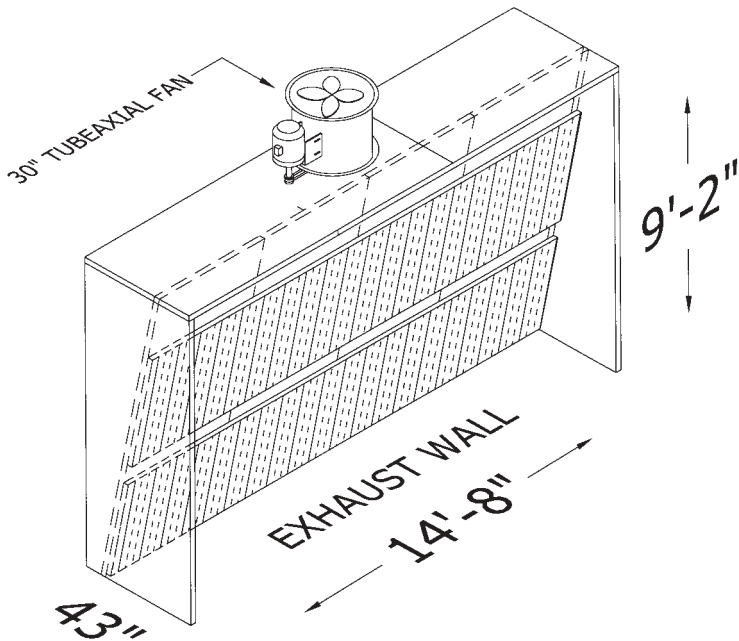
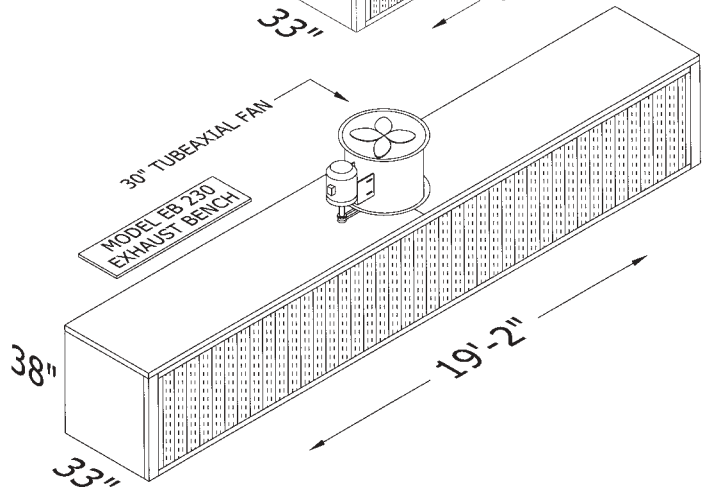
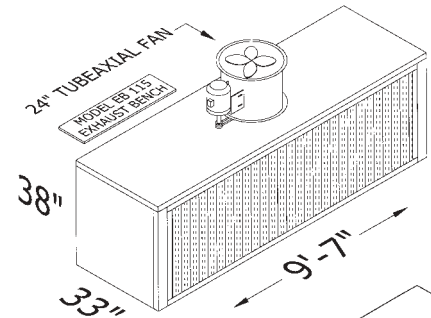

**CUSTOM
 SIZES
 AVAILABLE**

Exhaust Wall

18 Gauge galvanized steel panels
 Exhaust Filter "AFTL" Certified @ 99.6%
 30" Exhaust Fan, Hazard location approved
 3 HP, 208/230/460V 3PH, TEFC, HzLo, Motor



"WE'VE GOT THE ANSWERS"